



POWER PINS® 2.0 KIT

INSTALLATION AND STRINGING PROCEDURE

INSTALLATION

1. IDENTIFY THE PINS, THERE ARE 3 PAIRS, MARKED "B" FOR "LOW E & A", "M" FOR "D & G", AND "T", FOR "B & HIGH E". AS SHOWN IN (FIG.1)
2. PRE-ASSEMBLE THE POWER PLATE, 1 SCREW, 1 FLAT WASHER, 1 LOCK WASHER AS SHOWN IN (FIG. 2)
3. LOCATE THE BASS "E" PIN HOLE FROM INSIDE THE GUITAR, AND PUSH SCREW TIP UP INTO HOLE, PRESS THE POWER PLATE AND SCREW FLAT UP AGAINST THE BRIDGE PLATE.

IMPORTANT! TIP OF SCREW MUST BE APPROXIMATELY 1/16" - 1.5 MM BELOW THE SURFACE OF THE BRIDGE, IF IT IS PROTRUDING INTO THE SLOT, IT WILL INTERFERE WITH STRINGING. IF THE SCREW TIP IS TOO HIGH, THEN ADD FLAT WASHERS, UNTIL IT IS THE PROPER DISTANCE BELOW THE SURFACE. AS SHOWN IN (FIG.3)

4. POSITION A "B" POWER PIN IN THE BASS "E" HOLE FROM THE TOP, AND HAND TIGHTEN THE SCREW AND PRE-ASSEMBLY, FROM THE INSIDE. LEAVE THE ASSEMBLY FAIRLY LOOSE, SO THAT THE POWER PINS CAN BE EASILY ALIGNED IN THE CORRESPONDING POWER PLATE HOLES.
5. FOLLOW THE PROCEDURE IN STEP 2 WITH A "T" POWER PIN IN THE HIGH "E" PIN HOLE.
6. MOUNT THE REMAINING POWER PINS IN THE CORRECT HOLES.
7. TIGHTEN THE SCREWS WITH THE SUPPLIED 7/64" ALLEN WRENCH TO SNUG. A SMALL NUDGE ON THE WRENCH PAST SNUG IS ALL THAT IS NECESSARY TO KEEP THE POWER PINS PROPERLY POSITIONED. DO NOT OVER TIGHTEN.

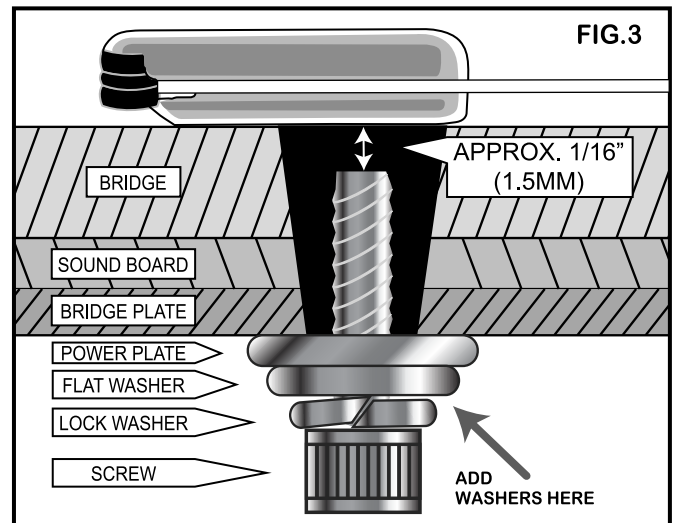
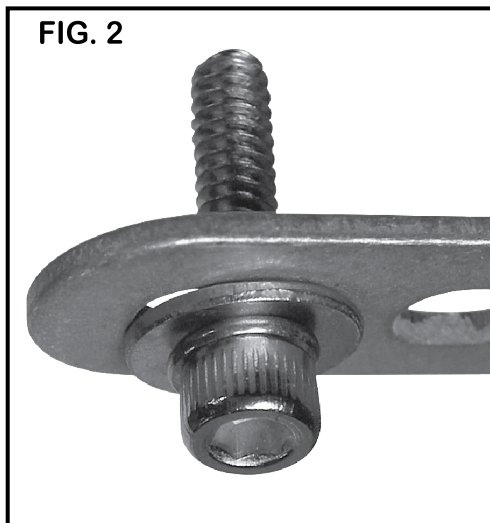

STRINGING PROCEDURE

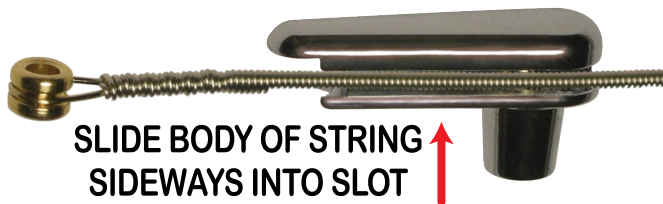

STRING RECOMMENDATIONS: GAUGES 0.13-0.56 SOME HEAVIER GAUGES OF SILK AND STEEL STRINGS MAY BE INCOMPATIBLE.

FOR TECH SUPPORT CALL (310) 929-0049 OR EMAIL US AT INFO@F1PICK.COM

POWER PINS AND POWER PLATE ARE TRADEMARKS OF BIGROCK ENGINEERING ALL RIGHTS RESERVED U.S. AND FOREIGN PATENTS PENDING ©2015